

AIRTECH AIR SUSPENSION

1. SHOCK ABSORBER

Heavy duty shock absorbers incorporating high damping characteristics helps eliminate wheel hop.

Fully contained within the suspension, mounted between the front hanger and the spring seat they are protected from road damage. This also allows for a more compact design giving a shorter stroke which reduces heat and increases service life. For most applications the shock absorber can also act as a check strap.

2. PIVOT BUSH

The exceptionally tough, metal encased Pivot Bush chosen for its very compact design, virtually eliminates rubber extrusion thus greatly extending its effective working life. The bonding of the bush material to the outer case and inner sleeve ensures the bush works in shear and cannot rotate. This compact design also permits front bracket reinforcing to be closer to the point of side load and reduces unwanted side movements.

3. SPRING

The shape of the spring contains the suspension geometry. AirTech has a standard rating of 12 tonne which is specially designed for arduous applications.

4. AIR SPRING

Using quality large diameter, low pressure air springs allows a reduction of the required air pressure at typical axle loads. A 4 bar system fed from a 6 bar air reservoir more readily maintains the correct ride height and trailer stability.

With the air spring including an internal bump stop, a long service life is expected.

5. AXLE SEAT

The design philosophy of the axle seat for AirTech is allowing for ease of fitment of the shocker during servicing.

6. AXLE

The axle, which serves as a torsion beam, is manufactured from 127mm diameter seamless manganese alloy steel, its high strength and resistance to bending characteristics are a critical part of the design of AirTech air suspensions.

- 16mm wall thickness suitable for highway operations.
- 19mm wall thickness suitable for off-road operations.

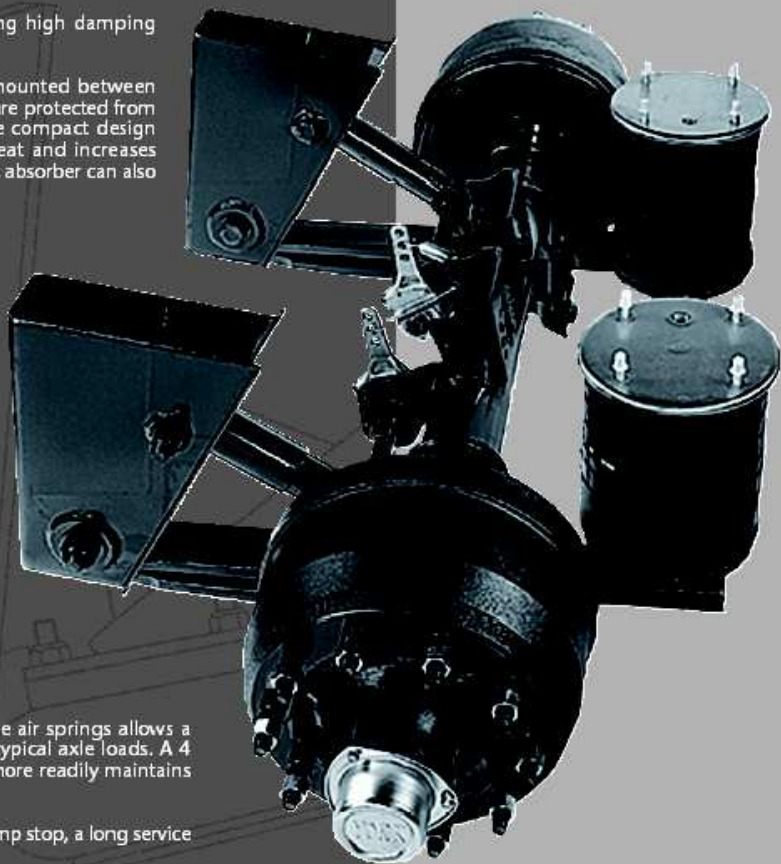

- Fewer components
- Proven reliability
- Low tare weights
- Easily accessible maintenance
- Good operating characteristics
- Suitable for both off-road & highway applications

The Perfect Balance

Quality, Reliability, Price and Excellent Services.



Rednet

AIR SUSPENSION

AIRTECH AIR SUSPENSION

Capacity:

12 tonne per module @ 80km/h
11 tonne per module @ 105km/h

Ride Height:

Available from 200mm to
600mm

Mounting Center:

960mm
(standard for 1850mm track
length)
Available for other length

Air Bag Centers:

800mm
(standard for 1850mm track
length)

Axle Seat:

Suit 127mm diameter round
beam axles
Suit 150mm diameter square
beam axles

Tare Weights:

200mm ride height - 210kg
400mm ride height - 228kg

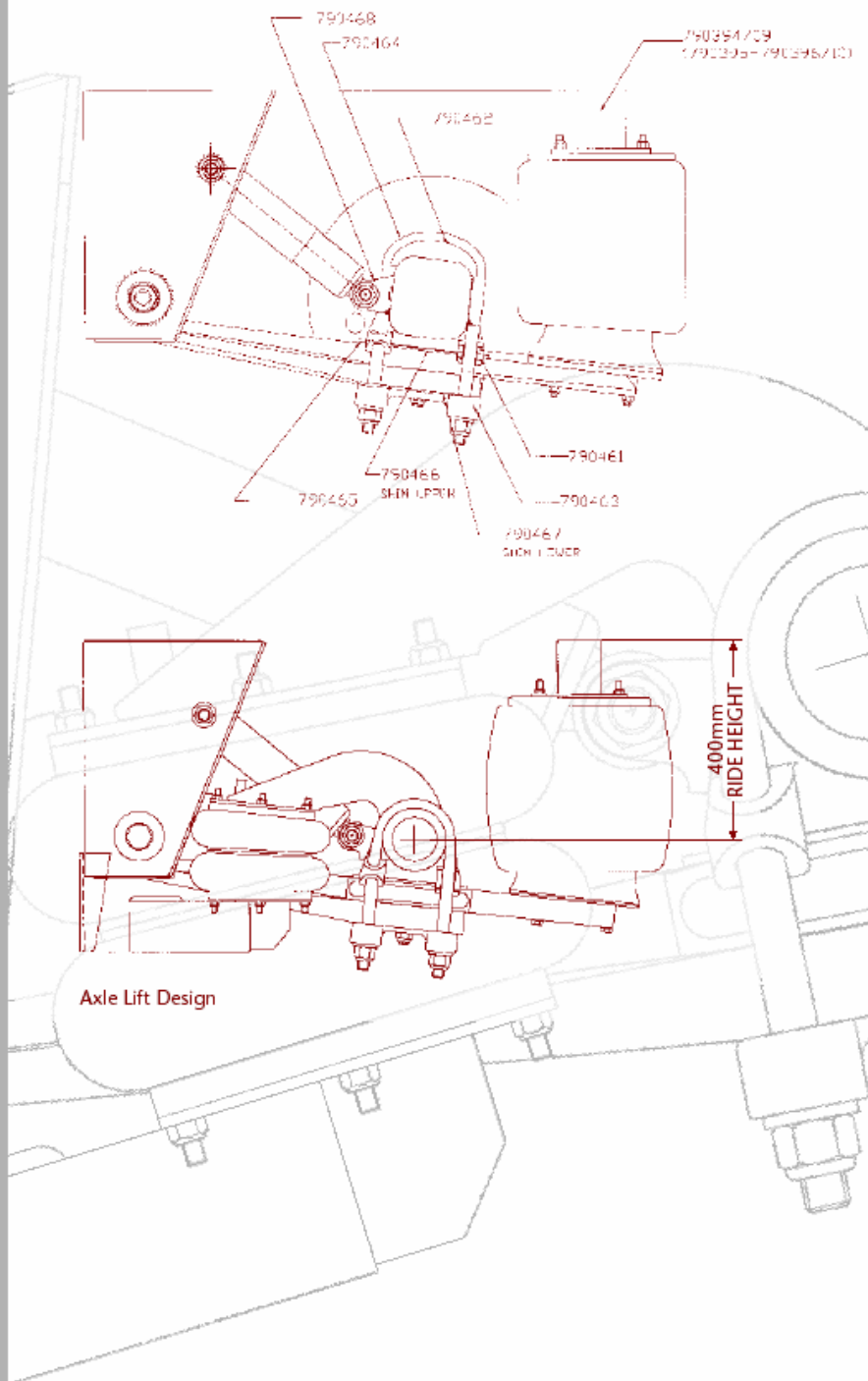

Rednet Pte. Ltd.

6 Pioneer Sector 1, Singapore 628418
Tel: 65-68978525 Fax: 65-68978231
Email: sales@rednet.com.sg
www.rednet.com.sg



Rednet